



Electra Steam, Inc.

4407 Martinsburg Pike
Clear Brook, VA 22624
USA

Phone: 540-662-3811
Fax: 540-665-8101
email: Sales@reimersinc.com
web: www.reimersinc.com

MODEL:

SERIAL #:

HLR 540kW – 900kW Hydronic Boilers



Instructions Manual

LIMITED WARRANTY – HOT WATER BOILERS

Reimers Electra Steam, Inc. warrants the following products of its own manufacture against defects in materials and workmanship under normal use and service. This warranty is in lieu and excludes all other expressed or implied warranties or merchantability of fitness for any particular use. No person is authorized to extend the terms of this warranty or assume any other liability except by written statement signed by an officer of Reimers Electra Steam, Inc. Clear Brook, Virginia 22624.

WARRANTY PERIOD

The pressure vessel, electrical and mechanical components are warranted for one year from date of shipment from Reimers Electra Steam, Inc. in Clear Brook, VA 22624.

LIMITATIONS

Products must be installed, used and maintained in accordance with our instructions, including reasonable and necessary maintenance by the user. Users are responsible for the suitability of the products to their application. There is no warranty damage resulting from improper installation, abuse, power failure, fire, flood, lightening, improper water, misuse, improper specification, misapplication or other operating conditions beyond our control or parts that are normally expendable in usual course of operation.

Claims against carriers for damage in transit must be filed by the buyer. Reimers liability, if any, will not exceed the price of Reimers products claimed to be defective.

Components manufactured by any supplier other than Reimers shall bear only that warranty made by the manufacturer of that product and service for that warranty shall be the responsibility of that manufacturer and not Reimers.

REMEDY

Claims under this Limited Warranty must be made by obtaining a Return Authorization Number from our office (PHONE: 540-662-3811, FAX: 540-665-8101) and returning defective part, freight prepaid to: Reimers Electra Steam, Inc., 4407 Martinsburg Pike, Clear Brook, Virginia 22624.

Defective items will be repaired or replaced as necessary within a reasonable time without charge, other than incidental charges such as freight prepayment. Such repair or replacement within a reasonable time is the exclusive remedy available from Reimers Electra Steam, Inc., under this Limited Warranty.

CONSEQUENTIAL DAMAGES

Reimers Electra Steam, Inc., is not liable for labor costs incurred in the removal, reinstallation, or unauthorized repair of product, or for damages of any type whatsoever, including incidental and/or consequential damages.

THIS WARRANTY SUPERSEDES ALL PREVIOUS WARRANTIES.



Read this manual before installing and using this product. Failure to do so can result in serious injury or death.

You have just purchased a quality hydronic boiler designed to the ASME Boiler Code and registered with the National Board of Boiler Inspectors. Treat this industrial equipment with care and respect. It is safe when installed, maintained, and used properly. Read the instruction carefully and contact the factory if you have any questions.

This manual contains safety messages. Each of the safety messages are preceded by one of the following signal word panels:

⚠ DANGER

Safety messages preceded by this label contain information, that if not followed will result in death or serious injury.

⚠ WARNING

Safety messages preceded by this label contain information, that if not followed could result in death or serious injury.

⚠ CAUTION

Safety messages preceded by this label contain information, that if not followed could result in minor or moderate injury.

NOTICE

Messages preceded by this label contain important information, but are not hazard-related.

Ensure that this manual is available to the boiler operator at any time.

Read carefully all safety labels attached to the boiler. If any safety label was damaged during shipment, contact the factory immediately:

Ph. 540-662-3811; e-mail: sales@reimersinc.com

Important Safety Information

⚠ WARNING

1. DRAIN VALVE: The Drain Valve is utilized to blow impurities from the boiler pressure vessel and/or drain the pressure vessel for inspection. When opened, a large volume of hot water and steam is discharged. Ensure that the Drain Valve is properly piped for such discharge. State and local codes must be met as applicable.

2. ELECTRICAL: All field wiring to the boiler must be in accordance with the National Electric Code and any local codes that may apply. Wiring must be performed by a competent certified electrician. Use copper wire only.

3. REPAIR: Repair of this unit must be attempted only by experienced personnel. Before commencing a repair, ensure that the boiler is cold, not pressurized, and electrically disconnected. All standard electrical and safety precautions must be taken during testing.

4. MODIFICATION/MISUSE: This boiler has been designed and constructed in accordance with the ASME Boiler Code. Any modification or misuse can result in a dangerous situation. Reimers Electra Steam, Inc. is not liable for any product that has been modified or improperly used.

5. PRESSURE GAUGE: The pressure gauge indicates the internal pressure of the boiler. It can fail. Periodically have your boiler inspector compare the gauge with a known gauge utilizing the test valve arrangement provided. Ensure that the boiler is cold, not pressurized and electrically disconnected.

6. REGISTRATION: Most states and cities require boiler registration and inspection. Check with your government authorities.

7. INSTALLATION AND REPAIR:

Installation and repair work of this unit must be performed only by experienced personnel. Before commencing a repair, ensure that the boiler is cold, not pressurized and electrically disconnected.

8. SAFETY VALVE: The safety valve is designed to discharge hot steam and/or hot water when the set pressure is exceeded. Ensure that the discharge port is pointing toward the back of the unit away from the operator or any aisles. Test the safety valve periodically to ensure that it is operating properly. Test carefully at full pressure by lifting lever using pliers and “slapping” shut. Steam discharge can scald. Ensure no one is exposed.

9. HOT WATER PIPE INSTALLATION:

Hot water piping must be of black pipe, not galvanized. Work must be done by an experienced plumber. All state and local codes must be met as applicable.

12. WATER:

Ensure that all electrical components are in a dry location, free from any possibility of water soaking.

1. Installation

Reimers Electra Steam Hot Water Boilers are heated by immersion-type heating elements. Automatic controls are provided to maintain pre-set operating temperature. Provision is included to connect the user's thermostat (120V AC) and circulating pump (120V). Safety features include automatic low water cut-off, automatic temperature high limit control, safety relief valve, and fuses on individual heater circuits.

Each boiler is designed to meet the requirements of ASME Standards and is individually inspected and stamped by an authorized National Board Insurance Inspector. All boilers are registered with the National Board of Boilers and Pressure Vessel Inspectors.

NOTICE

The ASME data plate is located on the right pressure vessel saddle, on the rear side of the boiler.

When boiler is received, make sure it has not been damaged in shipment.

1.1 Location

Place boiler in a level position as close as possible to the equipment to be supplied with heat. This will allow short pipe connections and minimum heat losses. Insulate all water lines where practical. Review the overall dimensions of your boiler model on page 5 to select proper boiler location.

a.) Working space:

Electric boiler spacing is dictated by NFPA-70, Table 110.26 as follows:

Nominal Voltage To Ground (Volts)	Minimum Clear Distance		
	Condition 1	Condition 2	Condition 3
0 – 150	3ft (91.4cm)	3ft (914mm)	3ft (914mm)
151 – 600	3ft (91.4cm)	3.5ft (107cm)	4ft (122cm)

Note: Where the conditions are as follows:

Condition 1 — Exposed live parts on one side of the working space and no live or grounded parts on the other side of the working space, or exposed live parts on both sides of the working space that are effectively guarded by insulating materials.

Condition 2 — Exposed live parts on one side of the working space and grounded parts on the other side of the working space. Concrete, brick, or tile walls shall be considered as grounded.

Condition 3 — Exposed live parts on both sides of the working space.

(a) *Dead-Front Assemblies.* Working space shall not be required in the back or sides of assemblies, such as dead-front switchboards or motor control centers, where all connections

and all renewable or adjustable parts, such as fuses or switches, are accessible from locations other than the back or sides. Where rear access is required to work on non-electrical parts on the back of enclosed equipment, a minimum horizontal working space of 762 mm (30 in.) shall be provided.

b.) Regardless of the above working space required by the National Electrical Code, leave at least 3ft (915 mm) clearance on both sides of the boiler for element servicing.

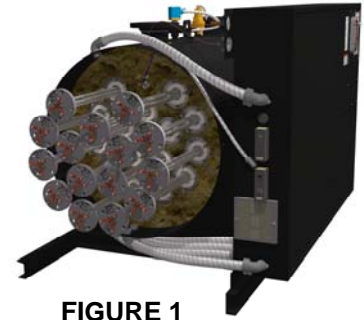

FIGURE 1

c.) Alcove or closet installation per UL834: Proper location of this boiler model with regard to combustible and noncombustible surfaces and materials is coded on the boiler name plate. The following decoding sketch and description is provided for the user information:

Model HLR210 through HLR510	Dimension in. (cm)						
	A	B	D	EL	ER	F	G
	24 (61)	A6 (A15)	6 (15)	6 (15)	6 (15)	C	-

Description of dimensions and symbols

A – Clearance above top of boiler

B – Clearance from front of boiler

Prefix C to numeral indicates suitability for closet or alcove installation

Prefix A indicates suitability for alcove but not for closet installation

D – Clearance from back of boiler

EL – Clearance from left side of boiler

ER – Clearance from right side of boiler

F – Indicates type of flooring: "NC" for noncombustible floor / "C" for combustible floor. Numeral indicates minimum clearance below suspended units to combustible floor

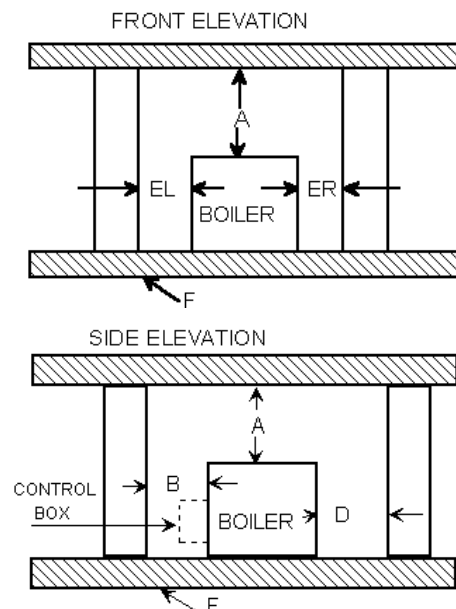

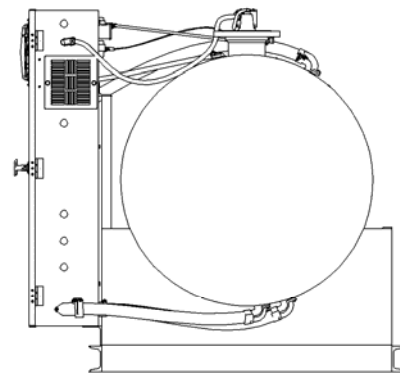
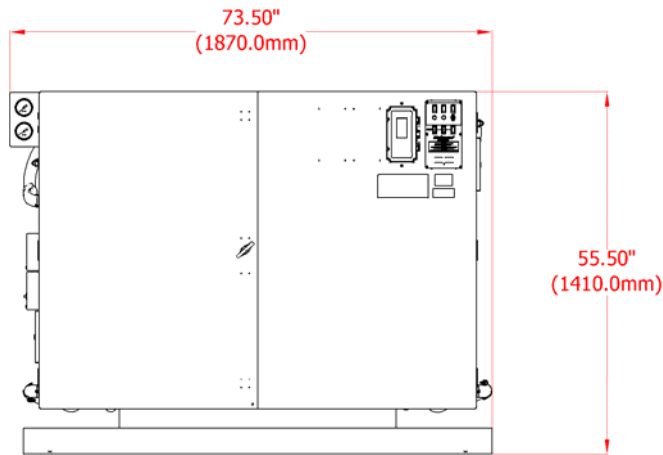
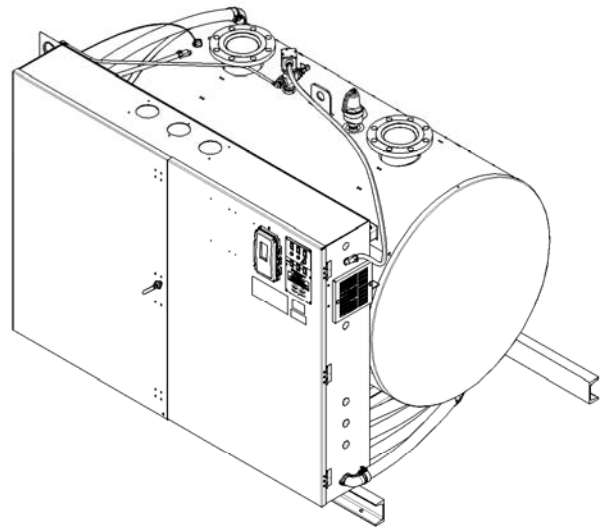
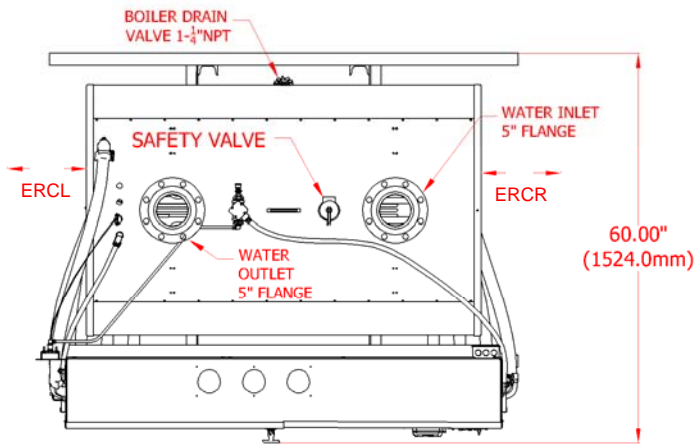

REQUIRED CLEARANCE FOR ELEMENT REMOVAL (ERCL & ERCR)
HLR540 – HLR900: ERCL = ERCR = 36" (915.0mm)

1.2 Heating Loop Piping

Piping: This hot water boiler is intended to be used in a closed pressure system with a circulating hot water pump. The boiler safety relief valve can have settings from 30 and up to 150psig. The expansion tank must be sized to meet the ASME standards for the overall water capacity of your heating system. The circulating system should also include an air trap and bleed, as well as automatic water fill. The water inlet and outlet are located on top of the boiler as shown in FIGURE 2.

Install stop valves as close as possible to the boiler supply- and return ports (FIGURE 2).

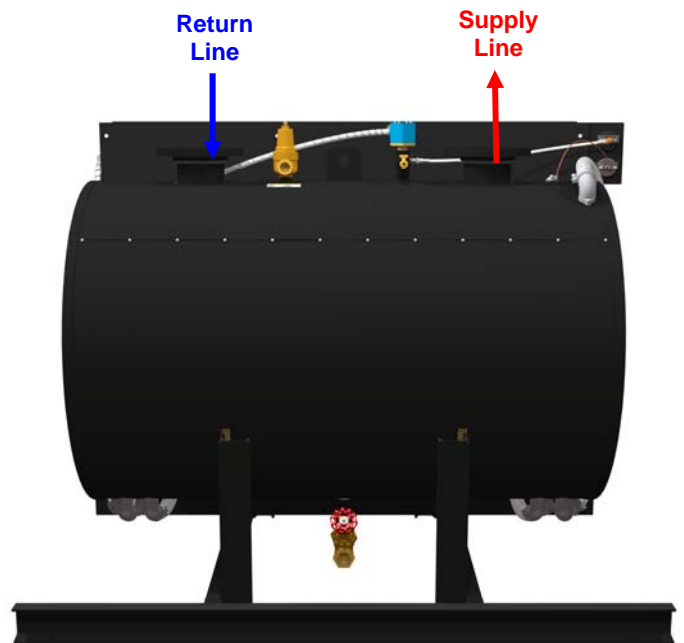

FIGURE 2

1.3 Safety Relief Valve

Safety Valve: If removed for shipment, install the safety relief valve directly on boiler without cut-off valves. Direct the discharge port of the valve so that scalding anyone if the valve discharges will be avoided. The discharge piping should never be smaller than the valve outlet and should be rigidly supported, placing no weight on the valve itself. Follow all installation instructions provided on the valve tag. Do not remove the tag from the valve!

⚠ WARNING Do not install valves into the safety relief valve piping.

1.4 Electrical Power Supplies

Each boiler – unless it is equipped with a control voltage transformer for single point power supply – requires two separate power supplies:

- a.) Control voltage of 120V AC, 60Hz on all boilers connected to, 480V or 600V, 3ph, 60Hz main power supplies and 220V – 240V, 50Hz on all boilers connected to 380V and 415V, 3ph, 50Hz main power supplies.
- b.) Main power supply of 480V, 600V, 3ph, 60Hz or 380V, 415V, 3ph, 50Hz.

Install a fused disconnect switch near the boiler. Connect the power supply from the disconnect switch to the terminals in the boiler control panel as shown below. Follow all state and local codes. If such codes don't exist, provide minimum ampacity of branch circuit conductors as indicated on the markings located near the field terminals.

Connect the circulating pump as indicated in the attached wiring diagram. The pump shall bear UL/CSA approval marking.

A copy of the wiring diagram is located in the control panel.

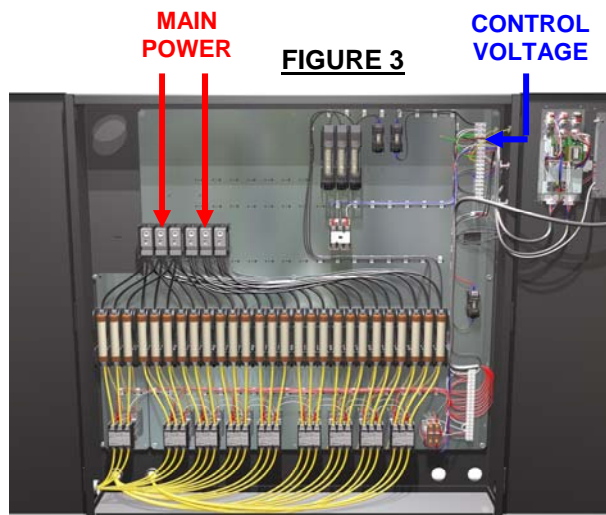

FIGURE 3

⚠ WARNING

Electrical connections to the boiler control panel should be made by a qualified electrician. All wiring must comply with local electrical codes.

NOTE: The number and size of electrical power terminals shown in FIGURE 3 vary, depending on boiler nominal voltage and installed heating power.

2. Operation

2.1 Boiler Startup

- a. With all power disconnected, check the control panel for loose wires caused by vibration in shipping. Review installation instructions to be sure boiler is properly wired and installed.
- b. Be sure that the boiler drain valve is closed
- c. Fill the system with water
- d. Ensure that the selector switch is in OFF-position (middle position)
- e. Turn on the control voltage power supply
- f. Turn the red POWER switch to the ON-position
- g. Start the circulating pump, or pumps by throwing the selector switch of the boiler controller into the PUMP-position. With pump running, bleed air from system and check entire system for leaks.
- h. This hot water boiler is equipped in its standard configuration with one temperature sensor, placed inside the boiler pressure vessel near the water outlet nozzle. It senses the water temperature as it exits the boiler. For space heating applications that require outdoor reset, a second sensor can be easily connected to the boiler controller in the field.

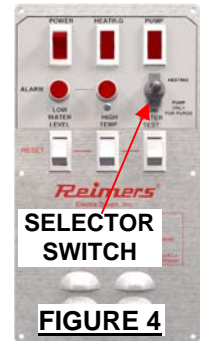

FIGURE 4

NOTE: For all boilers equipped with the Honeywell T775P2003 controller (standard configuration), please continue reading this paragraph. For all boilers equipped with the BACnet™ enabled controller, model OPT-HLR-BMS, please refer to the separate instruction manual that comes with the boiler.

The Honeywell controller T775P2003 was set at the factory with its parameters as shown below and to the operating water temperature as ordered:

Honeywell Controller T775P2003 Setup:

- 1.1 Entering Setup Mode: Press and hold the MENU button for 5 seconds to display the Setup menu
- 1.2. Setting up the Sensors:
 - 1.2.1. # of Sensors = 1
 - 1.2.2. Sensor A
 - 1.2.2.1. UNITS = DEG F
 - 1.2.2.2. CALIBRATE = 0.0°F
 - 1.2.2.3. LABEL = BOILER A
- > EXIT
- 2.3. SENSOR B = Not set, unless outdoor reset sensor connected to controller
- 1.2.4. SENSOR C: Not used
- > EXIT
- 1.3. Setting up the Outputs
 - 1.3.1. Number of STAGES = 4
 - 1.3.2. SCHEDULE = NO
 - 1.3.3. OPTIONS
 - 1.3.3.1. RESET = NO, unless outdoor reset sensor is connected to controller
 - 1.3.3.2. INTEGRAL = 0 sec.
 - 1.3.3.3. DERIVATIVE = 0 sec.
 - 1.3.3.4. ON DELAY = 0 sec.
 - 1.3.3.5. OFF DELAY = 0 sec.
 - 1.3.3.6. WWSD = NO
 - 1.3.3.8. LEAD LAG = FOFO
 - 1.3.3.9. DI OPTIONS = DISABLE
 - 1.3.3.10. SHOW RT = NO
- > EXIT
- 1.3.4. Setting up the Stages = Not set
- > EXIT
- 1.4. Setup Alarms = Not set
- > EXIT

Honeywell Controller T775P2003 Setting Operating Parameters

PROGRAMMING OUTPUT STAGES WITH NO RESET

- 3.1. Entering Program Mode: Press the MENU button, then select PROGRAM and press the > button to view the Program menu.
 - 3.1.1. SETPOINT = Set value to desired heating loop temperature
 - 3.1.2. THROTTLING RANGE = recommended range 15 – 25°F
 - 3.1.3. SENSOR = Not set
 - 3.1.4. HEAT/COOL = HEAT

To set the boiler controller for reset mode, please refer to the Honeywell T775P2003 boiler controller manual that is attached to this manual.

- i. Turn the three phase power supply ON
- j. Turn the selector switch into the HEATING-position

To set the boiler controller for reset mode, please refer to the Honeywell T775P2003 boiler controller manual that is attached to this manual.

2.2 Boiler Operation, Sequence of Events

a. As soon as the selector switch is in the HEATING-position and the Room/Process thermostat calls for heating:

HEATING light ON

PUMP light ON

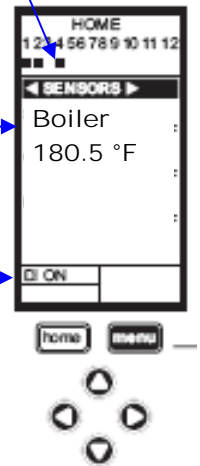

FIGURE 5

Both lights remain ON as long as the Room/Process thermostat calls for heating.

b. Depending on the difference between the programmed temperature set point and the actual temperature in the boiler pressure vessel, the boiler controller will start energizing heating stages. The energized heating stages are indicated in the controller display as black dots.

FIGURE 6



c. The actual temperature of the boiler is shown in the middle portion of the display. To change the set point, follow the instructions above (Honeywell Controller T775P2003 Setting Operating Parameters)

d. Various status messages may be shown in the lower portion of the boiler controller display. As long as the thermostat calls for heating, DI = OFF, when the thermostat does not call for heating, DI = ON.

e. As soon as the temperature in the pressure vessel approaches the programmed set point temperature, the boiler controller will begin to step out heating stages. If the actual temperature in the pressure vessel (temperature indicated on the temperature gauge) is higher than the programmed temperature set point, then the throttling range must be increased. If the actual temperature in the pressure vessels swings too high over the programmed set point, the high temperature safety limit control(s) may trip.

f. High Temperature Safety Limit Controls:

Pressure Gauge

Temperature Gauge

Automatic reset temperature high limit control

Manual reset temperature high limit control. Push red reset-button after temperature of water in boiler dropped below the setting of this control.

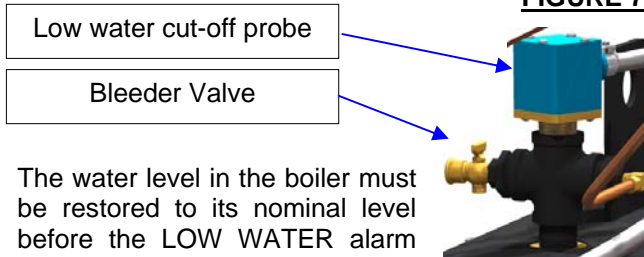

FIGURE 8

As soon as the water temperature in the boiler reaches the high limit setting, the heaters and the HEATING-light will turn off. This may occur when the system is brought up from cold to fully heated condition. In this case, increase the throttling range as described above. However, if the high limit control actuates repeatedly it would indicate that the water temperature setting is too close to the hi-limit setting. Check these settings and increase the difference between them. Each boiler is equipped with two high limit temperature safety limit controls: One automatic reset control, set to a lower cut-off temperature and one manual reset control, set to a higher cut-off temperature. If the automatic reset control trips, the HEATING light on the front panel of the boiler controller turns off and all heating stages turn off immediately. If the manual reset control trips, then the HEATING light on the front panel of the boiler controller turns off, the HIGH TEMPERATURE alarm light will turn on and all heating stages turn off immediately.

g. Low Water Cut-Off Safety Limit Controller:

Each hot water boiler is equipped with a low water cut-off control. If the water level in the boiler drops to a level below the tip of the low water cut-off probe, the HEATING light turns off, the LOW WATER alarm light on the front panel of the boiler controller turns on and all heating stages turn off immediately.



The water level in the boiler must be restored to its nominal level before the LOW WATER alarm can be reset. To reset this alarm, press the LOW WATER reset switch on the front panel of the boiler controller.

3. Maintenance

⚠WARNING	Repair must be performed only by experienced personnel. Ensure boiler is cold and drained and has no pressure or electricity.
-----------------	--

3.1 Re-Tightening the Electrical Terminal Connections inside the Electrical Enclosure and Pressure Vessel Jacket

Frequency: During boiler installation, 90days after boiler installation and then annual

Re-tighten the terminals of the contactors, fuse blocks and heating element terminals inside the electrical enclosure and pressure vessel jacket, following the maximum torque values listed below:

<u>Component</u>	<u>Maximum Torque</u>
50A-Contactor -----	25 in*lb
75A-Contactor -----	45 in*lb

Fuse Block -----	45 in*lb
Element Wires to Copper Lugs -----	20 in*lb
Copper Lugs to Element Terminals -----	12 in*lb

3.2 Testing the High Temperature Cut-Off Devices

Frequency: Once every six months

For this test, the boiler temperature should be near the boiler temperature setpoint and at least one heating stage energized.

3.2.1 Testing the Automatic Reset Temperature High Limit Safety Control

- Read the current boiler operating temperature setpoint
- Read and memorize the current setting of the automatic reset temperature high limit safety control
- Turn the dial of the temperature control towards the boiler temperature setpoint until all energized heating stages turn off together.
- Turn the dial of the temperature control to its initial position. The heating stages should energize staged in accordance with the programmed ON-delay time in the Honeywell step controller

3.2.2 Testing the Manual Reset Temperature High Limit Safety Control

Read the current boiler temperature boiler operating temperature setpoint

- Read and memorize the current setting of the manual reset temperature high limit safety control
- Turn the dial of the temperature control towards the boiler temperature setpoint until all energized heating stages turn off together. The HIGH TEMPERATURE alarm indicator light in the boiler controller panel should be ON.
- Turn the dial of the temperature control to its initial position. Press the red RESET button. The heating stages should energize staged in accordance with the programmed ON-delay time in the Honeywell step controller

3.3 Testing the Safety Relief Valve

⚠CAUTION	Before testing, make certain that the discharge pipe is properly connected to the valve outlet and arranged to contain and safely dispose of boiler discharge.
-----------------	---

Frequency: Under normal operating conditions test valve every two (2) months. Under severe service conditions or if corrosion and/or deposits are noticed within the valve body, testing must be performed more often. A test must also be performed at the end of any non-service period.

Test the safety relief valve (preferably near its maximum pressure setting by holding the test lever fully open for at least 5 seconds to flush the valve seat free of sediment and debris. Then release and permit the valve to snap shut.

3.4 Testing the Low Water Cut-Off Device: Checking the Heating Elements and Pressure Vessel for Corrosion and/or Deposits

3.4.1 Testing the Electronic Low Water Cut-Off Device Only

Frequency: Any time.

- Press and hold the LOW WATER CUT-OFF TEST switch on the boiler controller panel
- After 3 seconds, the HEATING indicator light – if it was ON – will turn OFF; the LOW WATER alarm indicator light will turn ON
- Press the LOW WATER RESET switch to deactivate the LOW WATER alarm

3.4.2 Testing the Entire Low Water Cut-Off System (Electronic Low water Cut-Off Device + Low Water probe)

⚠ WARNING	Maintenance work must be performed by experienced personnel only. Ensure boiler is cold and drained and has no pressure or electricity.
------------------	--

Frequency:

90 days after installation, then once every year

- Flip the boiler operating mode selector switch to the middle (OFF-position)
- Close the water inlet and outlet stop valves (FIGURE 10)
- Turn off and lock out all boiler power supplies
- Ensure that the boiler drain valve (FIGURE 10) is piped to a safe point of discharge
- Open the boiler drain valve carefully and drain the pressure vessel. As soon as there is no pressure present in the vessel, open the bleeder valve (FIGURE 7) slightly to break the vacuum

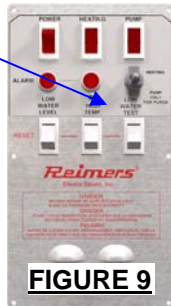

FIGURE 9

- Remove the left pressure vessel jacket end cap to access the heating elements
- Label the wires of two heating elements and disconnect from the terminals
- Remove the four (4) nuts from each heating element flange and pull the elements slowly out of the pressure vessel
- Inspect and if necessary remove with a stiff wire brush rust, calcium or other deposits from the element rods
- Insert a flash light through one heating element opening and inspect through the second opening the inner walls of the pressure vessel. It is normal that the inner walls of the vessel be covered by a layer of red, brown or black layer of rust. However, rough pressure vessel surface and layers of rust peeling off the surface are an indication for severe corrosion. In such case, contact a water treatment company.
- Install the heating elements back into the boiler pressure vessel, following the above procedure in reverse order.
- After installing the pressure vessel jacket end cap, turn on all power supplies of the boiler.
- Flip the red POWER switch of the boiler controller to the ON-position and leave the operating mode selector switch in the middle (OFF-position)
- Observe the LOW WATER alarm light in the boiler controller front panel. If it turns ON, the low water cut-off device works properly.
- Close the boiler drain valve, open the inlet and outlet valves and with the bleeder valve open, refill the boiler pressure vessel. Close the bleeder valve as soon as it discharges water.
- Press the LOW WATER RESET switch. The LOW WATER alarm light should turn OFF.
- The hot water boiler should be ready for operation.

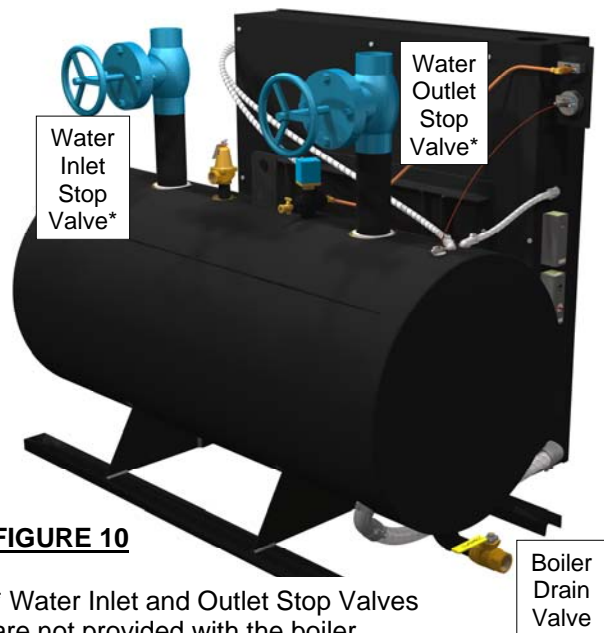

FIGURE 10

* Water Inlet and Outlet Stop Valves are not provided with the boiler

4. Trouble Shooting



Ensure that the boiler is cold and has no pressure. Electrical trouble shooting must be performed by a qualified electrician.

Boiler Status	Quick Fix
Control voltage to boiler turned on, POWER switch on boiler controller (5) turned ON, but no lights on the front panel of the boiler controller ON:	<ul style="list-style-type: none"> - Check circuit breaker or fuse of the wall outlet where the boiler control voltage circuit is hooked up to. If the circuit breaker is tripped or the fuse blown, check whether other appliances are plugged into outlets that are fed by the same circuit breaker/fuse. If that is the case, then plug those other appliances into outlets that are protected by other circuit breakers or fuses.
“Low Water” alarm light on boiler controller panel (5) ON:	<ul style="list-style-type: none"> - Press the “Low Water” reset button. If the “LOW WATER” alarm light remains on, check the water supply of the system. - Check whether the heating loop is filled with regular tap water and not with purified water (de-ionized, distilled, etc)
“HIGH TEMPERATURE” alarm light on boiler controller panel (5) ON:	<ul style="list-style-type: none"> - Press the “High TEMPERATURE” reset switch - If the temperature gauge indicates water temperature above the preset value, reduce water temperature setting and press the “HIGH TEMPERATURE” reset switch again.

If trouble shooting did not resolve problem, please contact our service technicians at:

Phone: 540-662-3811

Email: sales@reimersinc.com

LIVECHAT www.reimersinc.com

5. Parts List for Models HLR540 – HLR900

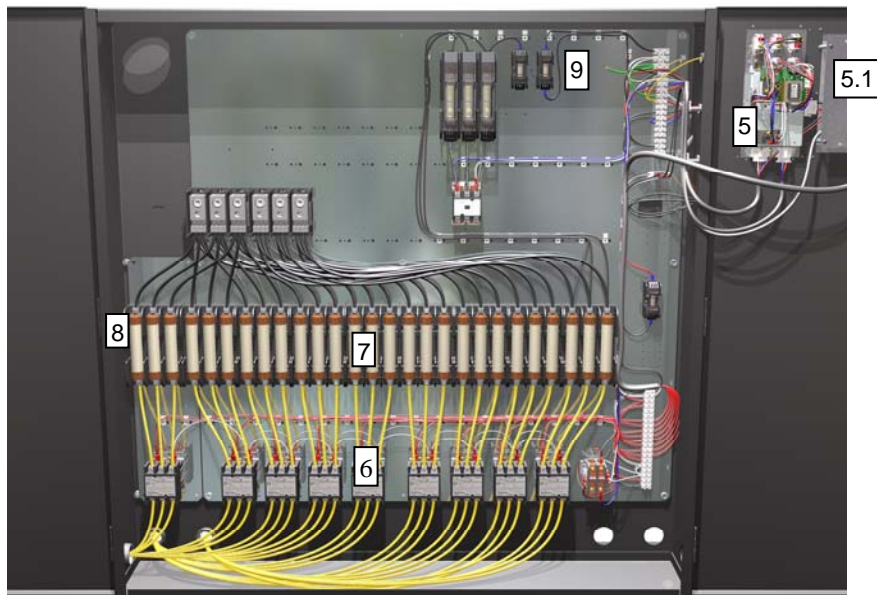
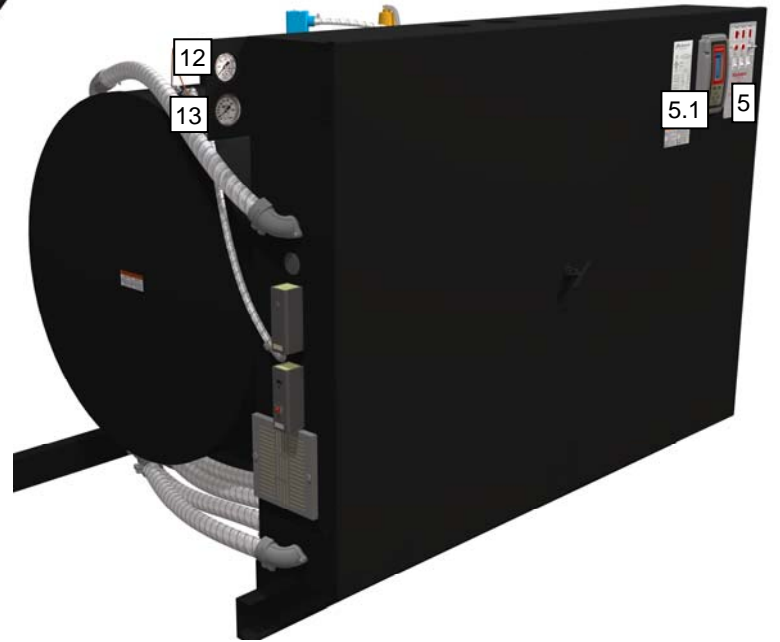
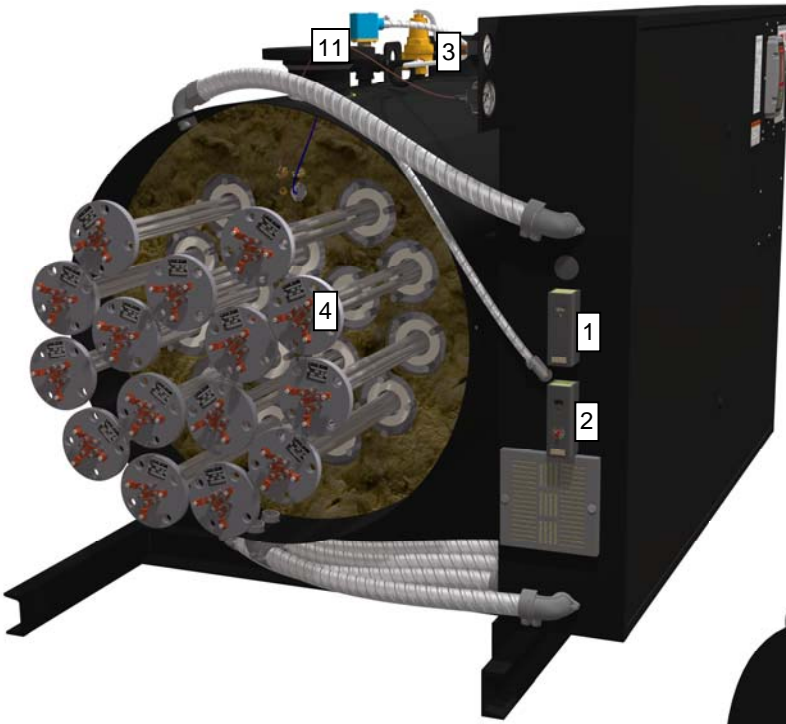

NOTE: When ordering parts, please provide boiler Model and Serial Number and detailed shipping instructions.

ITEM NO.	PART NO.	DESCRIPTION	BOILER MODEL
1	02378	TEMPERATURE CONTROL AUTO RECYCLE 100 – 240°F	ALL MODELS
2	02599	TEMPERATURE CONTROL W/MANUAL RESET	ALL MODELS
3	02657	VALVE SAFETY 0.75", 100psi HOT WATER	NOTE 2
	02384	VALVE SAFETY 0.75", 30psi HOT WATER	NOTE 2
	02706	VALVE SAFETY 0.75", 60psi HOT WATER	NOTE 2
	02641	VALVE SAFETY 0.75", 75psi HOT WATER	NOTE 2
	03357	VALVE SAFETY 1.5", 30psi HOT WATER	NOTE 2
	02560	VALVE SAFETY 1.0", 60psi HOT WATER	NOTE 2
	03358	VALVE SAFETY 1.0", 150psi HOT WATER	NOTE 2
4	02608	ELEMENT 30kW, 240V	NOTE 1
	03267	ELEMENT 30kW, 380V	NOTE 1
	02609	ELEMENT 30kW, 480V	NOTE 1
	02610	ELEMENT 30kW, 600V	NOTE 1
	02022	FLANGE GASKET	ALL MODELS
5	20721-HLR	ELECTRONIC BOILER CONTROL	ALL MODELS
5.1	05012	ELECTRONIC BOILER & STEP CONTROLLER	ALL MODELS
5.2	05019	ELECTRONIC STEP CONTROLLER EXPANSION MODULE	ALL MODELS
6	02530	HEATING ELEMENT CONTACTOR 50A 120V 3PH	NOTE 2
	02539	HEATING ELEMENT CONTACTOR 75A 120V 3PH	NOTE 2
	02597	HEATING ELEMENT CONTACTOR 93A 120V 3PH	NOTE 2
7	02656	HEATING ELEMENT FUSE 250V 90A UL/CSA	NOTE 2
	02135	HEATING ELEMENT FUSE 600V 40A UL/CSA	NOTE 2
	02519	HEATING ELEMENT FUSE 600V 50A UL/CSA	NOTE 2
	02136	HEATING ELEMENT FUSE 600V 60A UL/CSA	NOTE 2
	02138	HEATING ELEMENT FUSE 600V 80A UL/CSA	NOTE 2
	04972	HEATING ELEMENT FUSE 600V 90A UL/CSA	
	02137	HEATING ELEMENT FUSE 600V 100A UL/CSA	NOTE 2
8	02614	HEATING ELEMENT FUSE BLOCKS 600V 60A	NOTE 2
	02620	HEATING ELEMENT FUSE BLOCKS 600V 100A	NOTE 2
9	02125	CONTROL CIRCUIT FUSE 250V 15A UL/CSA	ALL MODELS
10	02140	CONTROL CIRCUIT FUSE BLOCK	ALL MODELS
11	02630	ELECTRODE PROBE FITTING	ALL MODELS
12	02569	PRESSURE GAUGE	ALL MODELS
13	02567	TEMPERATURE GAUGE	ALL MODELS
14	02515	DRAIN VALVE 1"	NOTE 2
	03209	DRAIN VALVE 1-1/4"	NOTE 2

NOTE 1 – When ordering, specify voltage (V) and power (kW) of element.

NOTE 2 – When ordering, specify model number of part.