

REIMERS ELECTRA STEAM, INC.

4407 MARTINSBURG PIKE
CLEAR BROOK, VA 22624-0037
PHONE: 540-662-3811 FAX: 540-665-8101
5/21/2004

MODEL:

SERIAL #:

MODELS R & RH 10 THRU 30
RB SERIES
ELECTRIC STEAM BOILERS

**INSTALLATION, OPERATING, &
MAINTENANCE INSTRUCTIONS**
Serial No.: 60903--63820

READ THIS FIRST

CAUTION:

**READ ALL INSTRUCTIONS BEFORE INSTALLATION/OPERATION.
ENSURE BLOWDOWN PROPERLY/SAFELY PIPED.
STAND CLEAR OF SAFETY VALVE & SCALDING STEAM.
VALVES/PIPES ARE HOT WHEN UNDER PRESSURE OR HEATING UP – DO
NOT TOUCH**

Reimers Electra Steam Boilers are heated by one or more immersion-type heating elements. Automatic controls are provided to maintain pre-set operating pressure and to keep the water supply at the proper level. Safety features include automatic low-water cut-off, automatic pressure control, safety pop-off valve and visible water level gauge.

Each boiler is designed to meet the requirements of ASME standards, and is individually inspected and stamped by an authorized National Board Insurance Inspector. All boilers are registered with the National Board of Boilers and Pressure Vessel Inspectors.

RETAIN THIS OPERATING MANUAL WITH BOILER. DO NOT DISCARD

REIMERS ELECTRA STEAM, INC.

4407 MARTINSBURG PIKE
CLEAR BROOK, VA 22624-0037
PHONE: 540-662-3811 FAX: 540-665-8101

5/21/2004

OPERATING INSTRUCTIONS

CAUTIONS: READ ALL INSTRUCTIONS BEFORE INSTALLATION/OPERATION.
VALVES/PIPES ARE HOT WHEN UNDER PRESSURE OR HEATING UP - DO NOT TOUCH.

ADJUSTMENTS:

All controls have been set at the factory and should require no adjustments.

MODIFICATION/MISUSE:

Any modification or misuse of this unit could result in a dangerous situation.
Reimers is not liable for any product that has been modified or improperly used.

REGISTRATION:

Most states/cities require boiler registration/inspection. Check local regulations.

REPAIR:

Repair of this unit must be attempted only by experienced personnel. (See Enclosed)

WATER:

All boilers must be blown down periodically to remove minerals, scale and other foreign matter which accumulate inside the pressure chamber. The concentration of this deposit depends in part upon the condition of the water in the area. When water is naturally soft, or has been softened chemically, blowdowns are required less often than in areas where hard water is found. Water softeners are suggested in hard water areas to minimize the formation of hard scale on heating elements. Another factor affecting water condition is the amount of condensate, if any, that is being returned to the boiler. Since condensate is essentially clean distilled water, it contains very few impurities. If a large part of the condensate is being returned and little make-up water is used, the boiler need not be blown down as often as when little or no condensate is returned to the boiler.

Chemical water treatment is not recommended for this design of electric boiler except as follows.

RECOMMENDED WATER QUALITY

ABMA (American Boiler Manufacturer's Association) recommends the following feedwater quality:

Total dissolved solids	3500 ppm max
Suspended solids	300 ppm max
Total Alkalinity	700 ppm or PH = 9.5 to 10.5

The above values are also referenced in Marks' handbook.

Following our research, we are concerned with hardness, PH and undissolved solids. Feedwater can be filtered, softened and adjusted for PH prior to entering boiler. Our recommendations are:

PROPERTIES	TREATMENT
Hardness less than 17ppm (1 grain)	Ion exchange water softener
PH between 10 and 11.5	Consult water treatment expert for PH inducer
Undissolved solids less than 300 ppm	Consult water treatment expert for filter

Note: Our electronic water level controls require a specific resistivity not greater than 25KΩ/CM

The recommendations we make do not guarantee no water related problems. There are many factors which affect water quality which we can not evaluate.

*For details, contact a water softening company in your area.

BLOWDOWN IS AN ESSENTIAL PART OF BOILER OPERATION.

IT IS THE BEST PREVENTIVE MAINTENANCE YOU CAN GIVE YOUR BOILER.

ENSURE A BLOWDOWN SCHEDULE IS ESTABLISHED & FOLLOWED REGULARLY.

WATER LEVEL CONTROLS MUST BE KEPT CLEAN TO INSURE PROPER OPERATION. SINCE WATER QUALITY CAN VARY, WATER LEVEL PROBES MUST BE INSPECTED AND CLEANED PERIODICALLY. WE SUGGEST EVERY THREE MONTHS AT A MINIMUM. (.5" PLUGGED HOLE HAS BEEN PROVIDED IN HEAD OF BOILER TO ASSIST IN PROBE MAINTANCE).

INSTALLATION

1. LOCATION: Place boiler in a level position as close as possible to the equipment to be supplied with steam. This will allow short steam connections and minimum heat losses. Cover all steam lines with insulation. Ensure that all electrical components are in a dry location not subject to steam or water.

IMPORTANT:

If installing the boiler in a confined area, leave the following clearances for servicing elements. Other installation dimensions are referenced on enclosed "RECOMMENDED BOILER INSTALLATION PARAMETERS" sheet.

(A) Allow 24" clearance at element end for servicing of Models 10 thru 30.

2. WATER SUPPLY: On models with pump and/or solenoid valve, connect incoming water supply to strainer on intake side of solenoid valve. On models furnished with condensate return tank, connect water line to makeup valve located at tank end.

3. STEAM OUTLET: Connect steam line of sufficient size from steam line valve to the equipment. Steam piping must be of black pipe, not galvanized. Work must be done by an experienced steamfitter. All state/local codes must be met.

4. CONDENSATE RETURN: If the condensate is to be returned by gravity (no tank & no steam trap) in a closed system, the load discharge should be at least 2 feet above the boiler water level. When applicable install steam return lines at sufficient height to allow a pitch of 2 inches to 10 feet of pipe length. To make the return connection to boiler, remove the boiler blow down valve install a tee and a close nipple and replace the blow-down valve, connect the return line with a swing check valve to the side opening of the tee with flow towards the boiler.

Where a significant amount of intermittent live steam is being taken from a line over 25 to 30 ft. in length, this system is not recommended.

5. CONDENSATE RETURN SYSTEM (WITH TANK): See Instruction Supplement #1.

6. SAFETY VALVE: Safety valve is designed to discharge hot steam when the set pressure is exceeded. Ensure that the discharge port is pointing toward the back of the unit away from the operator & any aisles. If it is required that discharge piping be installed from the safety valve, the pipe must never be smaller than the valve outlet & must be rigidly supported, placing no weight on the valve itself.

7. ELECTRICAL: All wiring must be installed in accordance with the National Electric Code & any local codes that may apply. Wiring must be done by a competent, certified electrician. For this service, the N.E.C. requires supply wires rated at 125% of full load. Use only copper wire. Install a fused disconnect switch within sight of the boiler. Connect power supply to the terminals in control panel .

8. BLOWDOWN VALVE: When the blowdown valve is utilized a large volume of hot water & steam is discharged. Ensure that this valve is properly piped for this discharge. State and local codes must be met as applicable.

OPERATION

1. Close the boiler drain valve, open gauge glass valves, top and bottom, & open steam line valve slightly to allow air to escape.

2. Turn on main water supply.

CAUTION:

Be sure water supply line to boiler is OPEN before turning on main power.
On models furnished with pump, never let pump run dry.

3. Throw main disconnect switch (main power supply) and power switch to ON position. This allows water to enter the boiler. On all models the water will automatically shut off when the water reaches the proper operating level.

4. Push "low water" manual reset switch. This turns on power to the heating elements. Now close the steam valve to allow pressure to build up.
5. When boiler has reached working pressure, open steam valve slowly by making 2 or 3 half turns during a period of about 2 minutes, then open the valve fully. Keep this valve open while boiler is in operation.

PRESSURE ADJUSTMENT: Turn knob on operating pressure control (see fig 2) clockwise to increase & counterclockwise to decrease. Be careful that safety valve does not lift. Do not adjust high limit pressure control. This control is factory preset. If the boiler pressure goes higher than the high limit pressure control setting, the "HIGH PRESSURE" light will be lit and the power to the elements will be shut down. To resume operation check operating pressure control and if necessary replace.

Caution: When replacing pressure switches boiler must be disconnected from electricity and no Pressure. Push "HIGH PRESSURE" reset switch to resume operation

6. **TO SHUT OFF BOILER:** Turn the "POWER" switch to the OFF position. Throw main power supply disconnect switch to OFF. Leave steam line open allowing pressure to drop normally and boiler to cool off slowly.

MAINTENANCE

CAUTION:

REPAIR MUST BE BY EXPERIENCED PERSONNEL.
ENSURE BOILER IS COLD/DRAINED AND HAS NO PRESSURE/ELECTRIC.
ALL ELECTRICAL/STEAM SAFETY PRECAUTIONS MUST BE TAKEN.

1. **BLOWDOWN:** Turn power off, allow pressure to drop to 5 psig, & open each blowdown valve for approximately ten (10) seconds.

CAUTION: STAND CLEAR OF SCALDING WATER/STEAM. ENSURE BLOWDOWN SAFELY PIPED.

FREQUENCY:

IN AREAS WHERE WATER IS SOFT OR HAS BEEN SOFTENED CHEMICALLY:

- a. When little condensate is returned BLOW DOWN ONCE EVERY WEEK.
- b. When a large part of the condensate returned and little make-up water is used
BLOWDOWN ONCE EVERY TWO WEEKS.

IN AREAS WHERE HARD WATER EXISTS:

- a. When little or no condensate is returned BLOW DOWN ONCE A DAY.
- b. When a large part of the condensate is returned and little make-up water is used
BLOWDOWN ONCE EVERY WEEK.

2. **PRESSURE ADJUSTMENT:** (FACTORY PRESET/SELDOM REQ'D)

CAUTION: STAND CLEAR OF SAFETY VALVE & SCALDING STEAM.

3. **SAFETY VALVE TEST:** (FREQUENCY-MINIMUM ONCE PER MONTH)

CAUTION: STAND CLEAR OF SAFETY VALVE & SCALDING STEAM.

NOTE: Safety valve should be tested at max. operating pressure.

1. Hold trip lever open for five seconds in order to flush off valve seat.
2. Permit valve to "slap" shut. (If leak occurs, repeat test or replace valve.)

4. **ELEMENT TEST: (CONDITION)** Unit will not heatup/maintain pressure, when power is on, unit is filled with water & pressure control is calling for steam.

1. **VOLTAGE TEST** = read rated voltage across each element. If **no** voltage reading, CHECK VOLTAGE BEFORE & AFTER EACH FUSE AND CHECK CONTROL VOLTAGE READING AT CONTACTOR. If voltage reads properly, GO TO STEP 2.

2. **AMPERAGE TEST** = read rated amps on each element wire. If **no** amp reading or unbalanced amp reading, replace element.

5. **ELEMENT CLEANING:** Use stiff wire brush & remove all scale/foreign matter.

6. **ELEMENT REPLACEMENT:**

CAUTION: ENSURE BOILER IS COLD/DRAINED & HAS NO PRESSURE/ELECTRIC

1. Open front cabinet door.
2. Disconnect and label terminal wires.
3. Remove 4 nuts from element flange and pull out heating element.
4. Clean flange surface before installing new element & gasket.

7. CONTROL CIRCUIT TEST: (CONDITION) Unit will not heat up when power is on, unit is filled with water & pressure control is calling for steam.

VOLTAGE TEST = read control voltage at incoming control circuit fuse & at each control point throughout system, i.e. low water control, hi-limit pressure control, operating pressure control (or step control if equipped), aux. low water cutoff (optional), and "POWER" switch. If voltage is not found at any one item in system, check out that item.

8. GAUGE GLASS REPLACEMENT: (FREQUENCY = MINIMUM ONCE PER YEAR)

CAUTION: ENSURE BOILER IS COLD/DRAINED & HAS NO PRESSURE/ELECTRIC. BE CAREFUL NOT TO BREAK GLASS

1. Close gauge glass valves (top and bottom).
2. Open petcock on bottom fixture of drain glass.
3. Loosen nuts at top and bottom of glass.
4. Slide glass up, pull out on bottom of glass and remove.
5. Install glass by reversing above procedure.

NOTE: Always install new rubber washers.

9. WATER FEED & LOW WATER CUTOFF:

1. Boiler does not take water: Check valve from city water & strainer clogging.
2. Boiler floods(cold water feed): Check solenoid for sticking.
3. Evaluate circuit board.

CAUTION: USE ONLY INSULATED ELECTRICAL WIRE FOR JUMPER. DISCONNECT ELECTRICAL POWER WHEN ATTACHING JUMPER OR CLEANING PROBE.

"REFILLING-LIGHT" Indicates pump/solenoid is on when lit. If water does not feed when "refilling light is lit, investigate pump / solenoid. If refilling light does not light when boiler water is low, remove probe wire from terminal "PR" (see wiring diagram). If light comes on, remove probe from shell and clean. If this does not resolve problem replace circuit board.

"LOW WATER"- ALARM LIGHT: When water level reaches half the length of gauge glass, " Low Water Alarm Light is on, " Low Water" reset switch is being pushed and "Low Water- Alarm Light remains on, then jump terminals "PR" and "GND" with an insulated jumper wire. If "LOW WATER"-Alarm Light goes off, remove probe from shell and clean. If this does not resolve the problem, replace circuit board.

10. PUMP MOTOR: Maintenance is not normally required on the pump or motor.

11. FUSE FAILURE: When a fuse blows, evaluate the following:

SHORT CIRCUIT HAS OCCURRED: Ensure line has been cleared, the cause of short circuit removed, then install the new fuse.

POOR CONTACT EXISTS: Poor contact on fuse can cause blowing. If surface that makes contact with the fuse clips is discolored, fuse has been making poor contact with the clips. Installing a larger fuse will not help. Replace the fuse holder.

12. FUSE REPLACEMENT:

1. **DO NOT** insert the fuse in live circuits, that will cause an arc that would cause a burr on the fuse cap which will prevent good contact with the clips.
2. If the insides of the clips and/or fuse caps are not bright and clean, brighten them with emery cloth.
3. If the fuse can be easily inserted into the spring clips or can be easily rotated after it is inserted, there is not sufficient contact pressure. Take the fuse out and draw the clips together.
4. If the clips have lost their spring, they should be replaced or clip clamps should be used. #1 for 0-30 amp/250 volt; #2 for 35-60 amp/250 volt Even if clamps are used be sure that the insides of clips are bright & clean.

13. CONTACTORS:

1. Ensure contactor coil is receiving proper voltage. The req'd voltage is stamped on the coil.
2. If voltage to coil is present, but contacts won't pull in, replace coil.

3. If contacts pull in, but contactor chatters: CLEAN/REPLACE CONTACT POINTS.
4. Further problems would indicate mechanical difficulties within the contactor (ie: springs, component parts).
5. Complete contactor replacement is normally the least expensive solution.

NOTE:

ASME DATA PLATE IS LOCATED ON END OF PRESSURE VESSEL BEHIND LABEL STAMPED WITH NATIONAL BOARD NUMBER OF UNIT.

FIG 1

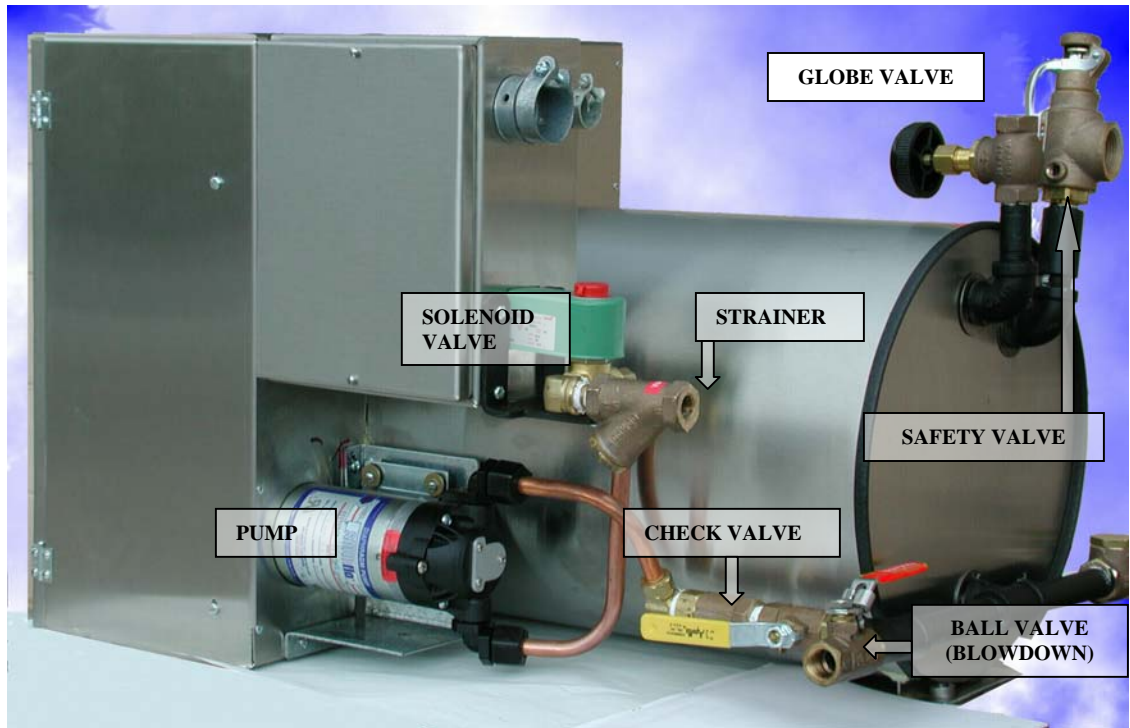
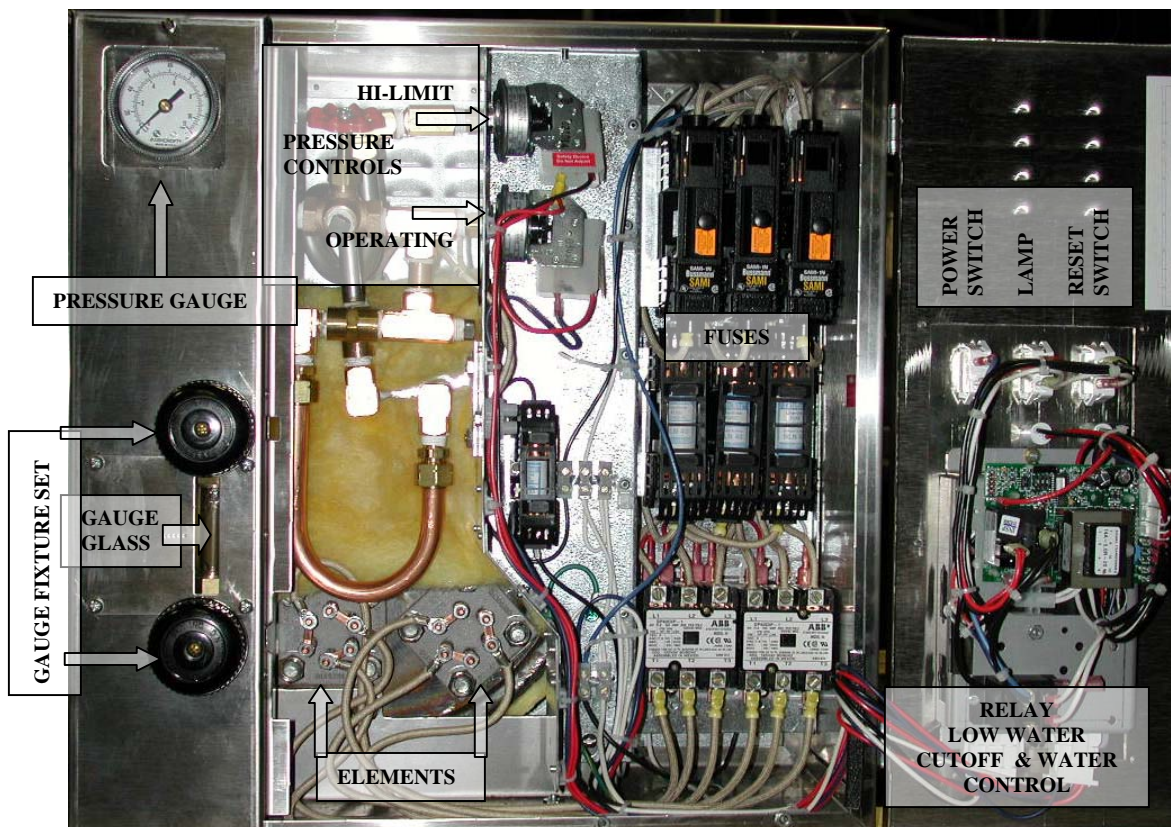

FIG 2



REIMERS ELECTRA STEAM, INC.
4407 MARTINSBURG PIKE
CLEAR BROOK, VA 22624-0037
PH: 540-662-3811 FAX: 540-665-8101
5/21/2004

PARTS LIST FOR
MODELS R & RH 10 THRU 30
(RB SERIES)

20422 COND TANK 11 GAL SQUARE W/VALVE
02530 CONTACTOR 50A 120V
02531 CONTACTOR 50A 240V 3P
04165 ELEMENT 240V 10KW 3PH
04253 ELEMENT 240V 15KW 3PH
02686 ELEMENT 240V 9KW 3PH
04153 ELEMENT 480V 9KW 3P
02125 FUSE 250V 15A
03470 FUSE 250V 3A
02127 FUSE 250V 60A
03349 FUSE 600V 80A CLASS J
02140 FUSE BLOCK 250V 30A
02142 FUSE BLOCK 250V 60A
03770 FUSE BLOCK 600V 100A 3P (FOR J FUSE)
02281 GASKET ELEMENT
04180 GAUGE GLASS .625" X 3"
02006 GAUGE RUBBER WASHER
02416 LIGHT RED 250V
04215 LIGHT RED W/WHITE 120V
04162 PRESSURE CONTROL 14# (HI-LIMIT OR OPERATING)
04163 PRESSURE CONTROL 91# (HI-LIMIT OR OPERATING)
02299 PRESSURE GAUGE 2"
02394 PRESSURE GAUGE XUC 0-30#
02360 PUMP 1/3 HP 120-240V 1P BURKS
04178 PUMP 120V 1PH POSITIVE
03774 PUMP 240V 1PH 50/60 HZ
04316 RELAY SOLIDSTATE CTRL
03262 STRAINER .375" Y
04213 SWITCH ILLUMINATED 120V
04214 SWITCH ILLUMINATED RED 250V
03943 SWITCH MANUAL RESET NC MO
02490 VALVE BALL .5" 200#
03346 VALVE BALL .5" W/LATCH
02370 VALVE CHECK .5"
02011 VALVE GLOBE .5"
02325 VALVE GLOBE 3/8"
02637 VALVE SAFETY .5"
02010 VALVE SAFETY .75" 15#
02585 VALVE SOLENOID .375 120V
02584 VALVE SOLENOID .375 240V
02396 WATER GAUGE SET

INSTRUCTION SUPPLEMENT NO. 1 CONDENSATE RETURN SYSTEM

The following Condensate Tanks are furnished as standard equipment on Model RHC Boilers, with Serial No. 17000 and up:

Tank size for Models 10 thru 30 ----- 11 gallons

INSTALLATION

1. Connect water supply to water intake on tank.

NOTE:

Water supply should be turned off when boiler is not in operation.

2. Connect condensate return line from equipment to condensate return intake.
3. Pipe from vent is to be installed to outside of building, if desired. If this method is used, pipe should be the same size as vent opening. Under no condition should vent be plugged.
4. Install piping from overflow to drain.
5. Pressure reducing valve required for city water pressures in excess of 40 PSI.

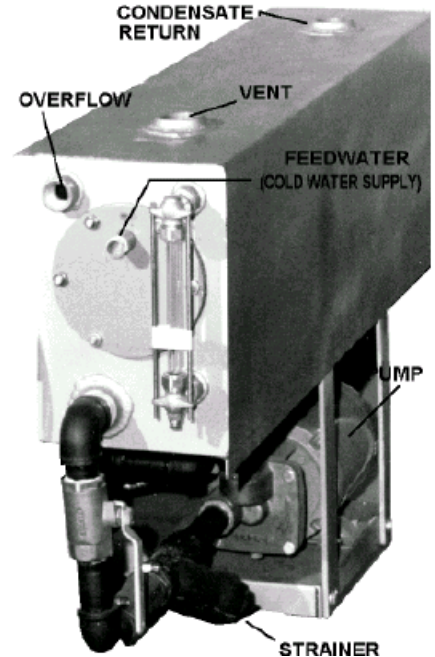

MAINTENANCE

1. **STRAINER** - should be removed and cleaned shortly after boiler has been in operation to clear away sediment which may have accumulated during start-up. This strainer should be periodically inspected and cleaned when necessary.
2. **GAUGE GLASS** - See boiler instructions.
4. **PUMP MOTOR** - Maintenance is not normally required on the pump or motor.

CONDENSATE RETURN SYSTEM PARTS LIST

PART#	DESCRIPTION
02005	GAUGE GLASS 5/8" X 7"
02001	GAUGE GLASS FIXTURE SET
02027	STRAINER 1"
02358	SCREEN FOR STRAINER
02360	PUMP/MOTOR 120/240 1PH 1/3 HP CT

MAKE-UP VALVE ASSEMBLY

(1) 02070	VALVE ASSEMBLY
(2) 02085	FLOAT BALL
(3) 02086	GASKET
(4) 02024	COMPLETE ASSEMBLY

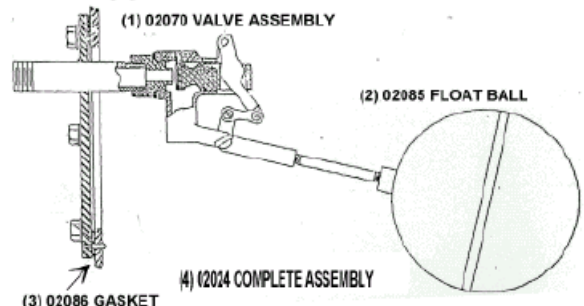

REIMERS ELECTRA STEAM, INC.

4407 MARTINSBURG PIKE
 CLEAR BROOK, VA 22624-0037
 PHONE 540-662-3811 OR FAX 540-665-8101

RECOMMENDED BOILER INSTALLATION PARAMETERS

PROPER LOCATION OF EACH REIMERS BOILER WITH REGARD TO COMBUSTIBLE AND NONCOMBUSTIBLE SURFACES AND MATERIALS IS CODED ON THE BOILER NAMEPLATE. THE FOLLOWING DECODING SKETCH AND DESCRIPTION IS PROVIDED FOR THE USER INFORMATION

MODEL	A	B C2	D	EL	ER
JR./AR 3-9	12"	12"	12"	12"	12"
RA 9-18	18"	18"	18"	13"	18"
R-RH-RHC 10-20	18"	18"	18"	24"	18"
R-RH-RHC 30	18"	24"	18"	24"	18"
R-RH-RHC 45-80	18"	24"	18"	24"	24"
R-RH-RHC 100-125	18"	24"	18"	36"	36"
R-RH-RHC 150	18"	24"	18"	46"	46"
RLP 100-200	18"	24"	18"	46"	46"
RLP 225-300	18"	24"	18"	46"	18"
RLP 350-500	18"	36"	18"	46"	46"
RHP 100-200	18"	24"	18"	46"	46"
RHP 225-500	18"	36"	18"	46"	46"
HMR 10-25	12"	24"	12"	18"	12"
HLR 12-20	18"	18"	18"	24"	18"
HLR 24-54	18"	24"	18"	24"	18"
HLR 60-108	18"	24"	18"	24"	24"
HLR 125-210	18"	24"	18"	36"	36"
HLR 225-500	18"	36"	18"	46"	18"

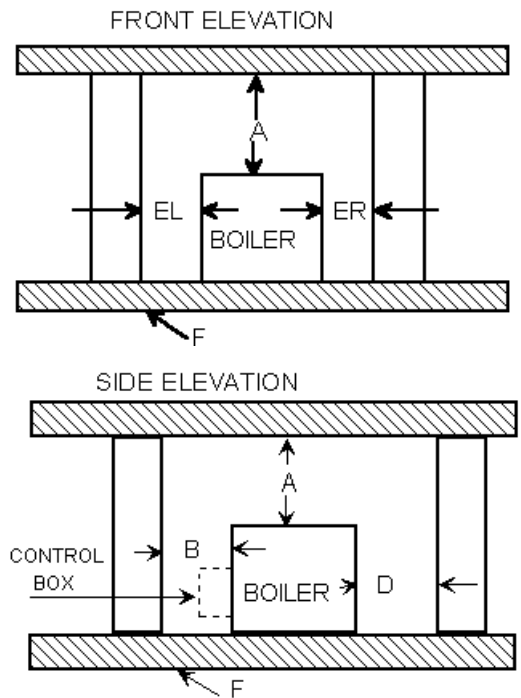

DESCRIPTION OF DIMENSIONS & SYMBOLS

A-CLEARANCE ABOVE TOP OF BOILER

B-CLEARANCE FROM FRONT OF BOILER PREFIX C TO NUMERAL INDICATES SUITABILITY FOR CLOSET OR ALCOVE INSTALLATIONS.

PREFIX A INDICATES SUITABILITY FOR ALCOVE BUT NOT FOR CLOSET

D-CLEARANCE FROM BACK OF BOILER

EL -CLEARANCE FROM LEFT SIDE OF BOILER

ER- CLEARANCE FROM RIGHT SIDE OF BOILER

F- INDICATES TYPE OF FLOORING: "NC" FOR NONCOMBUSTIBLE / "C" FOR COMBUSTIBLE .

NUMERAL INDICATES MINIMUM CLEARANCE BELOW SUSPENDED UNITS TO COMBUSTIBLE FLOOR

NOTE :IMPORTANT THE ABOVE DIMENSIONS DO NOT TAKE INTO CONSIDERATION THE PERIODIC NEED TO REMOVE THE HEATING ELEMENTS . FOR THESE ALLOWANCES PLEASE REFER TO PAGE 1 ,ITEM 1 OF INSTALLATION INSTRUCTIONS